

 Hypercharge
home
LEVEL 2 EV CHARGER

Installation Instructions

Support:

support@hypercharge.com

+1 (888) 320-2633



hypercharge.com







TABLE OF CONTENTS

1. IMPORTANT SAFETY INSTRUCTIONS	2
2. PRODUCT INTRODUCTIONS.....	6
3. VERIFY CONTENTS.....	8
4. GATHER TOOLS	10
5. PLAN THE MOUNTING.....	11
6. MOUNT THE CHARGING STATION	12
7. PLUG INTO WALL	13
8. OPERATING HYPERCHARGE HOME.....	14
9. LIGHT CODES	16
10. WARRANTY AND MAINTENANCE.....	18

WARNING & CAUTION





1. Important Safety Instructions

1.1 Overall Warnings & Cautions





-  **WARNING:** To avoid fire, injury or death, carefully read and follow the instructions during installation, operation and maintenance.
 - **DO NOT** put fingers into the electric vehicle connector.
 - **DO NOT** use this product if the flexible power cord or EV cable is frayed, insulation-broken, or any other signs of damage.
 - **DO NOT** use this product if the enclosure or the EV connector is broken, cracked, open, or shows any other indication of damage.
 - **DO NOT** remove cover or attempt to open the enclosure because of risk of electric shock.
-  **WARNING:** This device should be supervised when used around children.
-  **WARNING:** This device must be grounded.
-  **WARNING:** To avoid a risk of fire or electric shock, do not use this device with an extension cord.
-  **WARNING:** To reduce the risk of fire, connect only to a circuit provided branch circuit over-current protection in accordance with the CSA C22.1–15 Canadian Electrical Code, Part 1 (Canada) or NOM-001-SEDE Electrical installations (utility) (Mexico) or ANSI / NFPA 70 National Electrical Code (USA).

WARNING & CAUTION

1.2 Installation Requirements

-  **REQUIREMENT:** A NEMA 14-50 outlet connected to a dedicated 40A or 50A circuit breaker is required BEFORE installation of the Hypercharge Home charger.
-  **WARNING:** If you do not have a NEMA 14-50 outlet, consult a qualified electrical contractor to have a NEMA 14-50 outlet installed in accordance with local electrical code.
-  **CAUTION:** The device shall be mounted at height between 600 mm and 1200 mm from ground.
-  **CAUTION:** Please keep the charger in a clean area with low humidity. Not recommended to be installed in coastal environments with high humidity or high dust.







1.3 Daily Maintenance

-  **CAUTION:** Avoid moisture or water in the charger. If there is water or moisture ingress in the charger, it is necessary to immediately power off to avoid immediate danger, and notify the professionals to carry out maintenance before next use.
-  **CAUTION:** Please use the charger properly. Do not hit or press hard on the enclosure. If it is damaged, please contact a professional technician.
-  **CAUTION:** Avoid placing the charger near hot objects and at high temperature locations and away from dangerous substances such as flammable gases and corrosive materials.
-  **CAUTION:** Do not put heavy objects on the charger to avoid danger.

WARNING & CAUTION





1. Consignes De Sécurité Importantes

1.1 Avertissement & Mise En Garde Généraux





-  **AVERTISSEMENT** : Pour éviter les risques d'incendie, de blessure ou de mort, il faut lire et suivre soigneusement les instructions pendant l'installation, l'utilisation et l'entretien.
 - **Ne mettez pas** les doigts dans le connecteur du véhicule électrique.
 - **N'utilisez pas** ce produit si le cordon d'alimentation flexible ou le câble EV est effiloché, isolé ou présentant tout autre signe de dommage.
 - **N'utilisez pas** ce produit si le boîtier ou le connecteur EV est cassé, fissuré ou montre toute autre indication de dommage.
-  **Ne retirez pas** le couvercle et n'essayez pas d'ouvrir le boîtier en raison du risque de choc électrique
-  **AVERTISSEMENT** : Cet appareil doit être surveillé lorsqu'il est utilisé à proximité d'enfants.
-  **AVERTISSEMENT** : Cet appareil doit être mis à la terre.
-  **AVERTISSEMENT** : Pour éviter tout risque d'incendie ou de choc électrique, n'utilisez pas cet appareil avec une rallonge électrique.
-  **AVERTISSEMENT** : Pour réduire les risques d'incendie, ne connectez qu'à un circuit de protection contre les surintensités des circuits de dérivation conformément à la norme canadienne CSA C22.1-15 Code électrique, partie 1 (Canada) ou NOM-001-SEDE Installations électriques (Mexique) ou ANSI / NFPA 70 National Electrical Code (États-Unis).

WARNING & CAUTION

1.2 Exigence Avant L'installation

-  **EXIGENCE**: Une prise NEMA 14-50 connectée à un disjoncteur dédié de 40 A ou 50 A est requise AVANT l'installation du chargeur Hypercharge Maison.
-  **AVERTISSEMENT** : Si vous n'avez pas de prise NEMA 14-50, consultez un entrepreneur en électricité qualifié pour faire installer une prise NEMA 14-50 conformément au code électrique local.
-  **MISE EN GARDE** : Cet appareil doit être monté à une hauteur entre 600 mm et 1200 mm du sol.
-  **MISE EN GARDE** : Veuillez conserver le chargeur dans un endroit propre et peu humide. Il n'est pas recommandé de l'installer dans des environnements côtiers à forte humidité ou à forte poussière.

1.3 Entretien Quotidien

-  **MISE EN GARDE** : Évitez l'humidité ou l'eau dans le chargeur. En cas d'infiltration d'eau ou d'humidité dans le chargeur, il est nécessaire de l'éteindre immédiatement pour éviter tout danger immédiat et d'avertir le personnel professionnel d'effectuer l'entretien avant la prochaine utilisation.
-  **MISE EN GARDE** : Veuillez utiliser le chargeur correctement. Ne frappez pas ou n'appuyez pas trop fort sur le boîtier. Si le boîtier est endommagé, veuillez contacter un technicien professionnel.
-  **MISE EN GARDE** : Évitez de placer le chargeur à proximité d'objets chauds et à des endroits à haute température et loin de substances dangereuses telles que des gaz inflammables et des matériaux corrosifs.
-  **MISE EN GARDE** : Ne placez pas d'objets lourds sur le chargeur pour éviter tout danger.

2. Product Introductions



CAUTION: Avoid placing Hypercharge Home near hot objects, high temperature locations, and away from dangerous substances such as flammable gases and corrosive materials.

2.1 Basic Interface

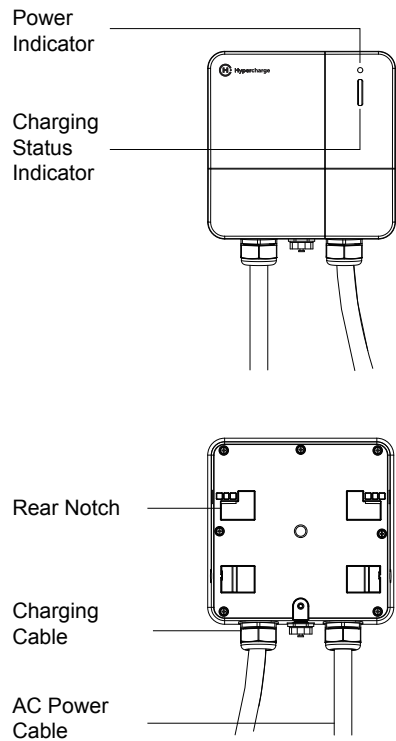

2.2 Basic Dimension

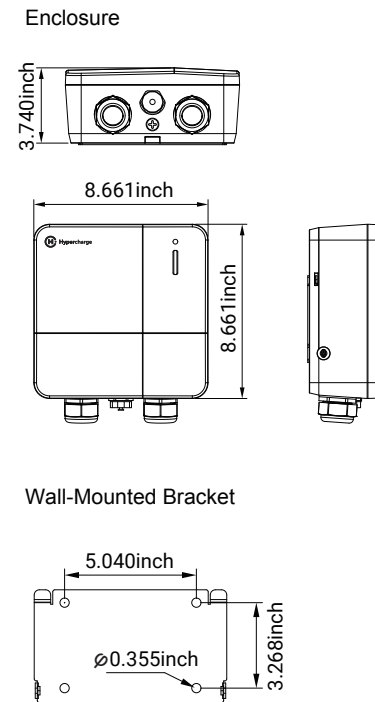

2.3 Specifications

Model Number	HC1117-JT (EVC27)
Rated Input Voltage	200-240 VAC
Rated Output Current	32A
AC Power Frequency	60 Hz
Input Protection	Undervoltage, Overvoltage, Residual Current, Surge, Ground Fault
Output Protection	Over Current, Over Temperature, Control Pilot Fault
Output Interface	SAE J1772 AC Charging Connector
Storage Temperature	-40°C to 70°C / -40°F to 158°F
Operation Temperature	-30°C to 50°C / -22°F to 122°F
Relative Operation Humidity	Up to 95% non-condensing
Relative Storage Humidity	Up to 95% non-condensing
Cable Length	18ft
Protection Level	Type 3 Enclosure
Installation Type	Wall-Mounted

3. Verify Contents

Check the box to ensure you have this installation guide and these parts:

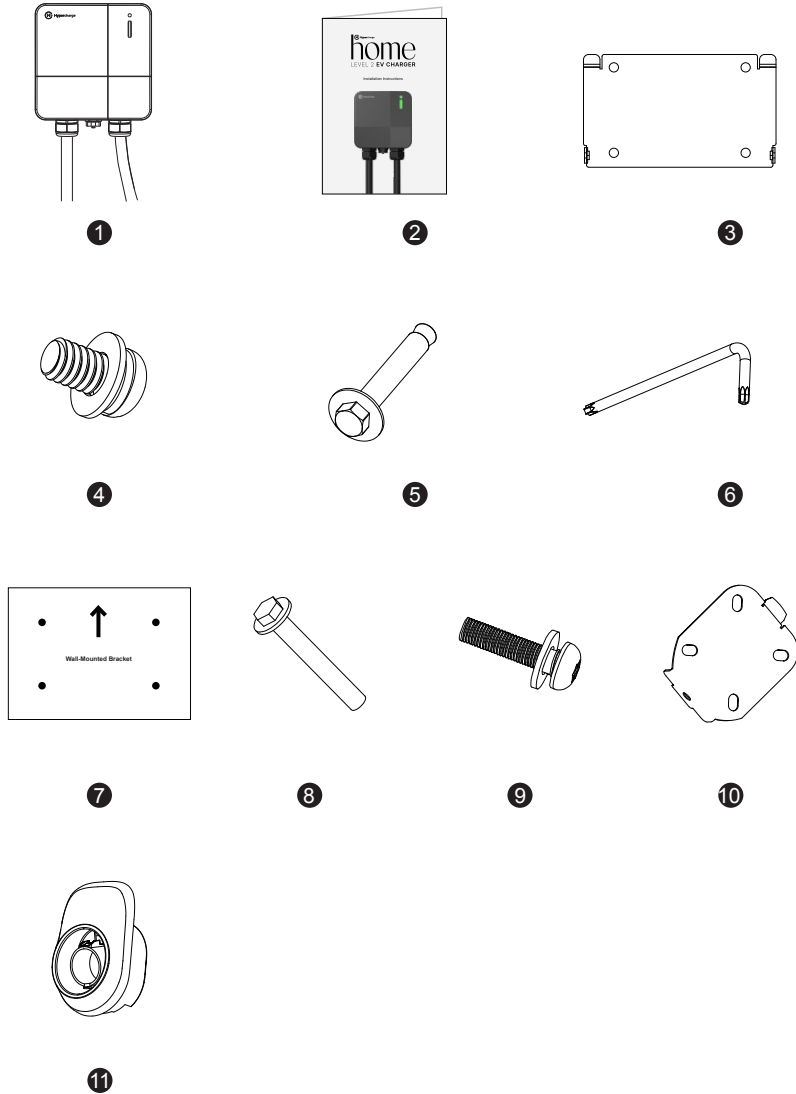

No.	Product Name	Quantity	Description
1	Hypercharge Home	1	With attached input power cable and output charging cable
2	User Manual	1	Please read carefully before use
3	Wall-Mounted Bracket	1	For mounting Hypercharge Home to the wall / structure
4	M5 Anti-Theft Round Head Screws	2	For securing Hypercharge Home to the Mounting Bracket
5	M6 Hexagonal Expansion Screws	4	For installing the Mounting Bracket to the wall / structure
6	Allen Wrench	1	For tightening M5 Screws
7	Corrugated Mounting Template	1	For easy drilling of 4 screws holes for wall-mounted bracket
8	M6 Anti-Theft Hexagonal Expansion Screws	4	For installing the Holster Bracket to the wall / structure
9	M5 Anti-Theft Countersunk Head Screws	1	For securing the Plug Holster to the Holster Bracket
10	Holster Bracket	1	For mounting the Plug Holster to the wall / structure
11	Plug Holster	1	For allowing the plugs to be neatly and safely stored when not in use

4. Gather Tools

Before installing Hypercharge Home, you will need the following tools:

1. Adjustable Wrench
2. Level
3. Pencil or marker
4. Drill



1

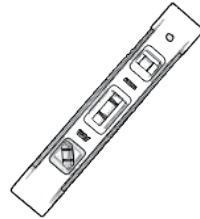

2

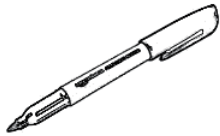

3



4

5. Plan The Mounting



WARNING: In areas with frequent thunderstorms, add surge protection at the service panel for all circuits. Ensure all power and ground connections, especially those at the breaker and bus bar, are clean and tight.

STEP 1

Select the appropriate mounting location for the charger and holster:

- I. Choose a mounting location that is within 3 feet (1000 mm) of your NEMA 14-50 outlet, and that allows the charging cable to reach the car's charging port while still providing slack.
- II. The device must be anchored into a mounting location such as a 2" x 6" stud or solid wall.
- III. The device shall be mounted at height between 2 feet (600 mm) and 4 feet (1200 mm) from the ground.

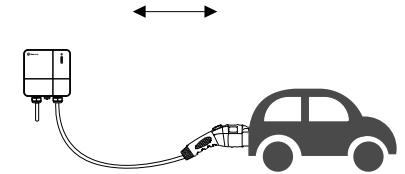

STEP 2

Install wall-mounted bracket for the charger: Use 4 Hexagonal Expansion Screws to secure the wall-mounted bracket (use anti-theft hexagonal expansion screws) to the wall. If mounting on a wood surface or drywall, use similarly sized wood screws and/or drywall anchors. Ensure the brackets are level.

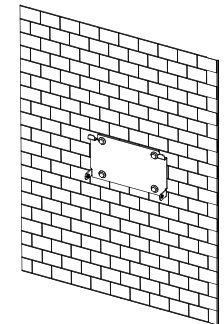

6. Mount the Charging Station and Holster

STEP 3

Mount charger on wall-mounted bracket: Align the rear notch of charger with the wall-mounted bracket and fit the screw holes of the right and left side.

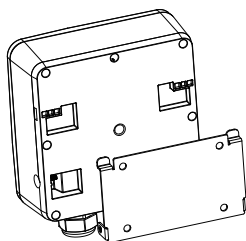

STEP 4

Secure charger onto wall-mounted bracket: Tighten two M5 anti-theft screws.

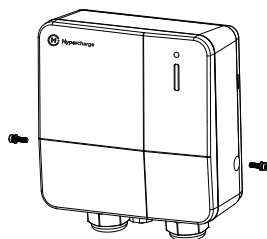

STEP 5

Install wall-mounted bracket for holster: Drill 4 screw holes with a diameter of 0.33" and a depth of 2.2". Use 4 holster bracket screws (M6*50mm external hexagon expansion screws) to secure the holster bracket on the wall, then level the brackets. If mounting on a wood surface or drywall, use similarly sized wood screws and/or drywall anchors.

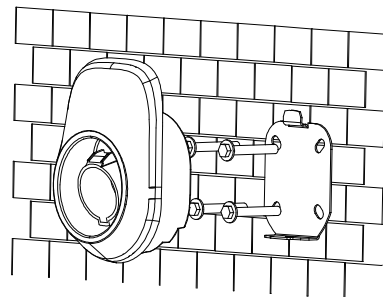
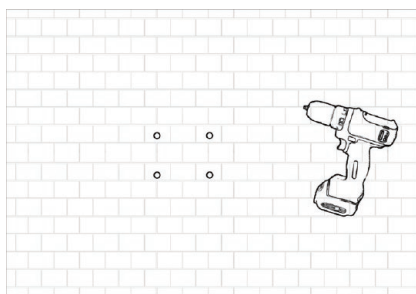

STEP 6

Secure holster onto wall-mounted bracket: Tighten one plug holster screws (M5*16mm anti-theft screws) to complete the installation.

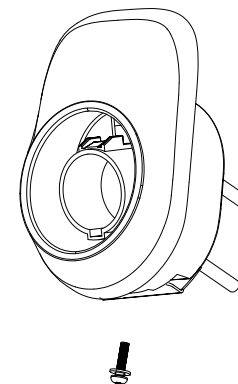

7. Plug into Wall

STEP 7

Plug charger into NEMA 14-50 outlet: If the circuit breaker for this NEMA 14-50 outlet was turned off, turn it back on. Follow the instructions on the next page to operate the Hypercharge Home.

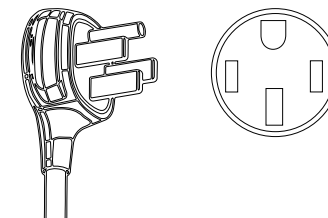

8. Operating Hypercharge Home



WARNING: Hypercharge Home is for adult use only.



CAUTION: Please operate Hypercharge Home correctly. Avoid striking or applying excessive force to the enclosure. If the casing is damaged, do not use.



CAUTION: Do not put heavy objects on Hypercharge Home.

8.1 Operating Steps

STEP 1

Power on and Standby:

After being powered on, all indicator colours — blue (READY), green (CHARGE), and red (FAULT) — will briefly appear. Once ready, the status indicator will turn solid blue (READY), indicating that Hypercharge Home is in standby and ready for use.

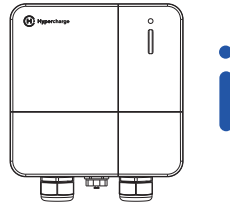

STEP 2

To Start Charging:

Plug the charging connector into the vehicle.



STEP 3

Charging in Progress:

When the status indicator light starts to flash green (CHARGE), Hypercharge Home is actively charging your vehicle.

- If the status indicator light is red (FAULT), remove the charging connector from the vehicle and plug it in again.
- If the status indicator light is still red, please refer to "Error and Warning Messages".

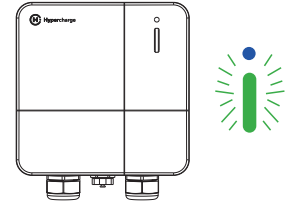

STEP 4

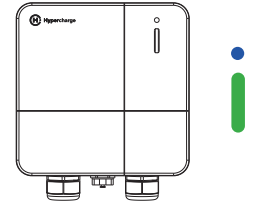

Charging Complete:

When charging is complete, the status indicator will turn solid green (CHARGE). Remove the charging connector from the vehicle.







9. Light Codes

9.1 Power Indicator

Power Off	Power On
	
Light Off	Solid Blue

9.2 Status Indicator

Standby, waiting to plug in	Waiting to charge, communicating with vehicle	Charging in progress	Finished charging	Fault
				
Solid Blue	Solid Green	Green Blinking	Solid Green	Solid Red

9.3 Error and Warning Messages

Fault Status	Red
Voltmeter fault	1 flash followed by 3 sec pause
Control pilot fault	2 flashes followed by 3 sec pause
Input Undervoltage	3 flashes followed by 3 sec pause
Input Overvoltage	4 flashes followed by 3 sec pause
OTP	5 flashes followed by 3 sec pause
OCP	6 flashes followed by 3 sec pause
Ground fault	7 flashes followed by 3 sec pauses
Relay fault	8 flashes followed by 3 sec pauses
RCD abnormal	9 flashes followed by 3 sec pauses
RCD self-test fault	10 flashes followed by 3 sec pauses

10. Warranty and Maintenance

- The warranty period for this charger is two years.
- During the warranty period for any malfunction under normal use according to the User Manual and Service Instructions (to be determined by certified maintenance technicians of sellers), the product shall be repaired free of charge. Except for the following situations, the charger shall be subject to the above warranty terms:
 1. The warranty certificate cannot be provided or the contents of the warranty certificate are modified or inconsistent with the label indication of the repaired product.
 2. Those who are unable to provide valid proof of purchase.
 3. Those who exceed the manufacturer's specified warranty period.
 4. Those who damage the product due to not following the product service instruction for use, maintenance and storage.
 5. Damage or malfunction caused by external object entering.
 6. Unauthorized repair, disassembly or modification.
 7. Damage caused by force majeure (such as lightning, excessive voltage, earthquake, fire, flood, etc.).
 8. Malfunction and damage caused by other unavoidable external factors. Malfunction and damage caused by improper use of equipment, such as water or other solutions entering into the equipment.
 9. Malfunction and damage caused by the grid power supply and voltage which is not specified for use with the charger equipment.

The above guarantees shall be made solely, and no other express or implied warranties shall be made (including the implied warranties of merchant ability, particular and applicable reason- ableness and adaptability, etc.) whether in the contract, civil negligence, or other aspects, the Company shall not be responsible for any special, incidental or consequential damages.